

# HUSKEE®

## VERTICAL/HORIZONTAL 35 TON LOG SPLITTER

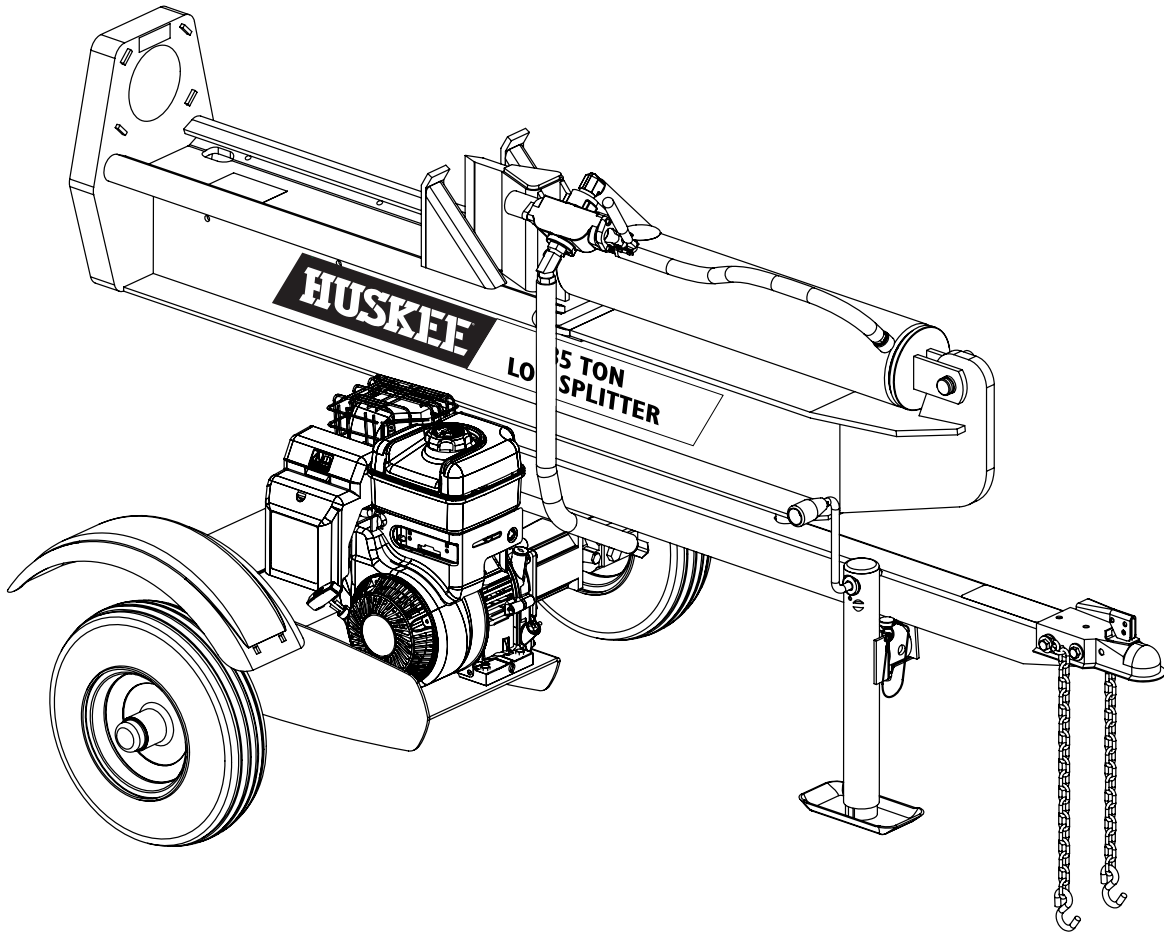

**MODEL NO. 21-52382**

# Owner's Manual

## ASSEMBLY & OPERATING INSTRUCTIONS



*This safety alert symbol identifies important safety messages in this manual. Failure to follow this important safety information may result in serious injury or death.*

# Table of Contents

	Page(s)
Important Safety Information.....	1-6
Intended Use .....	1
Personal Protective Equipment .....	1
Safety Decals .....	1-2
General Safety .....	3
Preparation of the Log .....	3
Work Area .....	3
Operation of the Log Splitter .....	3-4
Repair and Maintenance Safety .....	4
Hydraulic Safety .....	5
Fire Prevention .....	5-6
Towing Safety .....	6
Assembly Instructions .....	7
Operating Instructions .....	7-9
Engine Oil Recommendations .....	8
Starting Instructions .....	8
Operation .....	9
Towing .....	9
Maintenance .....	9
Parts List for Model 21-52382 .....	10-11
Parts Breakdown Illustration for Model 21-52382 .....	12
Notes .....	13
Specifications .....	Back Cover



# IMPORTANT SAFETY INFORMATION



**WARNING:** Read and thoroughly understand all instructions and safety information before assembling or operating this log splitter. Failure to do so may cause serious injury or death. Do not allow anyone to operate this log splitter who has not read this manual. As with all power equipment, a log splitter can be dangerous if assembled or used improperly. Do not operate this log splitter if you have doubts or questions concerning safe operation. Call our customer service department at 1-800-525-8322 to address these concerns.

*Si no entiende ingles, se prefiere que busque alguien que interprete las instrucciones para usted.*

## INTENDED USE

**NEVER** use this log splitter for any other purposes than splitting wood. It is designed for this use **only**. Any other use can cause serious injury or death.

## PERSONAL PROTECTIVE EQUIPMENT



**BEFORE** operating this log splitter make sure that you wear safety gear such as goggles or safety glasses, steel toed shoes and tight fitting gloves (without loose cuffs or draw strings). Always wear a protective hearing device when operating this log splitter.

**NEVER** wear loose clothing or jewelry that can be caught by moving parts of the log splitter. Keep clothing and hair away from all moving parts when operating this log splitter.

## SAFETY DECALS

Make sure that all safety warning decals are in good condition and readable. Always replace missing or defaced decals. Write us or call 1-800-525-8322 and they will be sent to you at no charge.



PART NUMBER: 5202000  
LOCATION: TOP, FRONT END OF TONGUE



# IMPORTANT SAFETY INFORMATION

**OPERATOR SAFETY**

**WARNING**



- Read and understand owner's manual thoroughly before operation. Failure to do so may result in serious injury. Manual also available online.
- Only one person should load and operate the log splitter. Keep all others away during operation. Never allow one person to operate the valve while another is positioning the log.
- Always position the log with hands on the sides of the log. Keep hands clear of ends.
- Do not operate log splitter under the influence of alcohol, drugs, or medication.
- Never check for leaks with your hands. High pressure fluid can escape through small holes and cause serious injury which could result in blood poisoning.
- Always stay in the operator zone when operating the log splitter.
- Keep hands, feet and clothing away from power driven parts.
- Do not attempt to step or reach over log splitter.
- Do not add gasoline while the engine is hot or running. Allow all spilled gas to evaporate before using log splitter.
- Always operate outdoors. Exhaust gases contain carbon monoxide. This odorless gas can be deadly when inhaled.

**CAUTION**

- Always wear safety glasses, safety shoes, and protective hearing devices during operation.
- Always shut off engine when leaving log splitter unattended, even for a short time.
- Always operate log splitter on level, dry, non-slippery surfaces. Keep off slopes.
- Keep work area clear of split wood, debris and other obstacles.
- Always split wood in the direction of the grain.

**OPERATING INSTRUCTIONS**

1. Read the Owner's manual for complete safety and operation instructions. Manual also available online.
2. Set up the log splitter in a clear, level area. Make sure that the suction port of the tank is always on the lower side of the log splitter.
3. Block the wheels. Lock the log splitter into either horizontal or vertical position.
4. Start the engine, refer to the Owner's manual and the Engine Operating and Maintenance manual.
5. Place a log on the beam against the foot plate. Position the log with hands on the sides. Make sure the log is securely placed against the foot plate and the beam.
6. Depress the valve handle so that the cylinder will drive the wedge/ram into the log.
7. Extend the cylinder until the log splits or to the end of the stroke. If the log has not completely split after the cylinder has reached the end of it's extension, retract the cylinder.

**Control Valve**

Retract ▲

●

Extend ▼

**For Responsive Service**  
Call 1-800-525-8322

51013200



PART NUMBER: 510105700  
LOCATION: TOP, FORWARD SECTION  
OF HYDRAULIC CYLINDER

**NOTICE**

KEEP TANK FILLED TO "OK" RANGE ON DIPSTICK. DO NOT FILL BEYOND "OK" RANGE. USE UNIVERSAL HYDRAULIC OIL OR DEXTRON II TRANSMISSION FLUID.



52023200

PART NUMBER: 52023200  
LOCATION: HYDRAULIC TANK  
LOWER TANK, RIGHT CORNER

PART NUMBER: 51018900  
LOCATION: TOP OF HYDRAULIC CYLINDER



# IMPORTANT SAFETY INFORMATION

## GENERAL SAFETY

**Failure to follow these instructions may result in serious injury or death.**

**NEVER** allow children to operate this log splitter. **NEVER** allow adults lacking proper instructions and understanding to operate this log splitter.

**KEEP** all people and pets a minimum of 10 feet away from your work area when operating this log splitter. Only the operator is to be near the log splitter during use.

If a helper is assisting in loading logs, **NEVER** actuate the control until the helper is clear of the work area.

**NEVER** operate the log splitter when under the influence of alcohol, drugs or medication.

**NEVER** allow a person who is tired or otherwise not alert to use your log splitter.

## PREPARATION OF THE LOG

Both ends of the log should be cut as square as possible to help prevent the log from riding out of the splitter during operation. Do not split logs greater than 26 in. in length.

## WORK AREA

**NEVER** operate the log splitter on slippery, wet, muddy or icy ground.

**ONLY** operate your log splitter on level ground. Operating on a slope could cause the log splitter to roll over or logs to fall off.

**NEVER** operate your log splitter in an enclosed area. Exhaust fumes contain carbon monoxide which can be deadly when inhaled.

**NEVER** attempt to move your log splitter over hilly or uneven terrain without a tow vehicle or adequate help.

**ALWAYS** block the wheels to prevent movement of the log splitter while in operation.

**ONLY** operate your log splitter in daylight or under good artificial light.

**ALWAYS** keep the work area clean. Remove split wood around your log splitter immediately so that you don't stumble over it.

## OPERATION OF THE LOG SPLITTER

**ONLY** operate the log splitter from the operator zone.

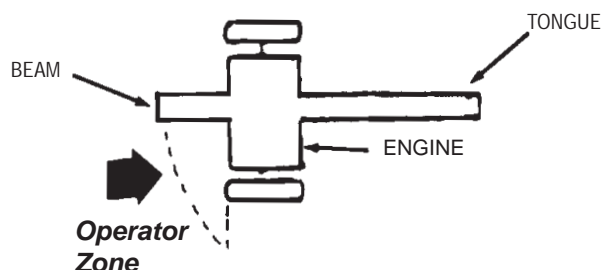



# IMPORTANT SAFETY INFORMATION

**KNOW** how to stop the log splitter and disengage the controls before operating it.

**NEVER** place hands or feet between the log and splitting wedge during forward or reverse stroke. Serious injury or death could result.

**NEVER** straddle or step over the log splitter during operation.

**NEVER** reach or bend over the log splitter to pick up a log.

**NEVER** try to split two logs on top of each other.

**NEVER** try to cross split a second log.

**NEVER** allow one person to operate the valve while another is positioning the log.

**NEVER** attempt to load your log splitter when the ram or wedge is in motion.

**ALWAYS** use your hand to operate the control lever on the valve. **NEVER** use your foot, a rope or any extension device.

**NEVER** move the log splitter while the engine is running. Shut off the engine even if you are leaving the log splitter for a short period of time.

**ALWAYS** avoid contact with the muffler and other hot areas of the engine during operation to prevent burns.

## REPAIR AND MAINTENANCE SAFETY

**NEVER** operate your log splitter when it is in poor mechanical condition or in need of repair.

Periodically check that all nuts, bolts, screws, hydraulic fittings and hose clamps are tightened.

**NEVER** alter your log splitter in any manner such as adding a rope or extension to the control lever or adding to the width or height of the wedge. Such alterations may cause your log splitter to be unsafe and will void the warranty.

Perform all recommended maintenance procedures before using your log splitter.

Replace all damaged or worn parts immediately.

**NEVER** tamper with the engine to run it at excessive speeds. The maximum engine speed is preset by the manufacturer and is within safety limits.

**ALWAYS** remove the spark plug wire before performing any service or repair on your log splitter.

**ALWAYS** check the level of hydraulic oil and engine oil before operation.

**ALL** replacement parts must meet manufacturer's specifications.



# IMPORTANT SAFETY INFORMATION

## HYDRAULIC SAFETY

The hydraulic system of your log splitter requires careful inspection along with the mechanical parts. Be sure to replace frayed, kinked, cracked or otherwise damaged hydraulic hose and components.

**NEVER** check for leaks of hydraulic fluid with your hand. Fluid escaping from a small hole can be almost invisible. Escaping fluid under pressure can have sufficient force to penetrate skin causing serious personal injury or even death. Leaks can be detected by passing a piece of cardboard over the suspected leak and looking for discoloration.

**ALWAYS** seek professional medical attention immediately if injured by escaping hydraulic fluid. Serious infection or reaction can develop if proper medical treatment is not administered immediately.

**ALWAYS** be sure to relieve all pressure by shutting off the engine and moving the valve control handle back and forth should it become necessary to loosen or remove any hydraulic fitting.

**NEVER** remove the cap from the hydraulic tank or reservoir while the log splitter is running. Hot oil under pressure could result in serious injury.

**NEVER** adjust the hydraulic valve. The pressure relief valve on your log splitter is preset at the factory. Only a qualified service technician should perform this adjustment.

## FIRE PREVENTION

**NEVER** operate your log splitter near a flame or spark. Hydraulic oil and gasoline are flammable and can explode.

**NEVER** fill the gas tank while the engine is hot or running. Allow the engine to cool before refueling.

**NEVER** smoke while operating or refueling your log splitter. Gas fumes can easily explode.

**ONLY** refuel your log splitter in a clear area with no gas fumes or spilled gas.

**ALWAYS** use an approved fuel container.

**ALWAYS** replace the gas cap securely.

If gasoline has spilled, move the log splitter away from the area of the spill and avoid creating any source of ignition until the spilled gas has evaporated.

**ALWAYS** take a Class B fire extinguisher with you when operating this log splitter in dry areas as a precautionary measure against possible flying sparks.

**ALWAYS** drain the fuel tank prior to storage to avoid the potential fire hazard.

**ALWAYS** store gasoline in an approved, tightly sealed container. Store the container in a cool, dry place.

**NEVER** store gasoline in the house or near a heating appliance.



# IMPORTANT SAFETY INFORMATION

## IMPORTANT NOTE:

This log splitter is equipped with an internal combustion engine and should not be used on or near any unimproved forest-covered, brush-covered or grass-covered land unless the engine's exhaust system is equipped with a spark arrester meeting applicable local or state laws (if any). If a spark arrester is used, it should be maintained in effective working order by the operator. In the state of California a spark arrester is required by law. Other states have similar laws. Federal laws apply on federal lands. A spark arrester muffler (optional by manufacturer) is available as an accessory at your nearest engine dealer. Always check the legal requirements in your area.

## TOWING SAFETY

**ALWAYS** check all local and state regulations regarding towing, licensing, and lights before towing your log splitter.

**ALWAYS** check before towing to make sure that the log splitter is correctly and securely attached to the towing vehicle and that the safety chains are secured to the hitch or bumper of the vehicle with enough slack to allow turning. Always use a Class I, 2" ball with this log splitter.

**NEVER** carry any cargo or wood on your log splitter.

**NEVER** allow anyone to sit or ride on your log splitter.

**ALWAYS** disconnect your log splitter from the towing vehicle before operating it.

**ALWAYS** be careful when backing up with your log splitter in tow. It could jackknife.

**ALWAYS** allow for added length of your log splitter when turning, parking, crossing intersections and in all driving situations.

**NEVER** exceed 45 mph when towing your log splitter. Towing the log splitter at speeds higher than 45 mph could result in loss of control, damage to the equipment, serious injury or death. Adjust towing speed for terrain and conditions. Be extra cautious when towing over rough terrain especially railroad crossings.



## ASSEMBLY INSTRUCTIONS

**NOTE:** This log splitter was partially assembled at the factory. Refer to the drawing and parts list should it become necessary to disassemble the unit for repair or replacement of parts.

**STEP 1:** Remove all the components from the crate. Inspect each piece for shipping damage. If any part is damaged, contact your dealer or delivering carrier.

**STEP 2:** Attach the tongue (3) to the tank/axle (2) as shown in the diagram using the two 1/2 in. NC x 4-1/2 in. hex cap screws (75), 1/2 in. lockwashers (77) and 1/2 in. NC hex nuts (76) from the hardware kit. Tighten. NOTE: Flatwashers are included in the hardware kit should it be necessary to use them as spacers to eliminate play between the tongue and the tank tongue mounting plate.

**STEP 3:** Attach the tongue jack (72) by aligning the hole in the tube on the jack with the hole in the bushing on the log splitter tongue (3). Insert the locking pin in the vertical position through the holes.

**STEP 4:** Remove the rubber covering from the two spindles on the tank/axle (2). The wheel bearing cups, bearing cones, grease seals and hub caps are already assembled. Bearing cones have been greased at the factory. Remove the blue, plastic protective covering from the wheel hubs. Mount the wheels (63) to the spindles on the tank/axle (2) using the 3/4 in. light flatwasher (68) and 3/4 in. slotted nut (69) from the hardware kit. There are two types of light flatwashers (68). Use the ones that best allow the wheel to rotate freely after the 3/4 in. slotted nut (69) is tightened down and bearing play is removed. Install the cotter pin (70) and the hub cap (71) from the hardware kit. Repeat step 4 for the other wheel.



**WARNING:** *At least two people are required to raise the beam to insure safety and prevent injury.*

**STEP 5:** Stand the beam (1) up on end. Check that the beam is stable. Remove the pivot pin (73) and the clip pin (74) from the tank/axle (2). Roll the axle/tongue assembly into position between the two tabs on the beam (1). Slide the pivot pin (73) through the holes and lock in place with the clip pin (74).

**STEP 6:** Connect the end of the 1/2 in. I.D. x 44 in. hydraulic hose (14) coming from the fitting (12) on the pump (9) to the fitting (49) on the valve (5) port.

**STEP 7:** Slide one hose clamp (13) on to the end of the 3/4 in. I.D. x 44 in. hydraulic hose (20) that comes from the fitting on the tank/axle (2). Then connect the hose to the fitting (47) on the valve (5). Tighten hose clamp.

**STEP 8:** Attach the fenders (79) to the tank/axle (2) using the 1/4 in. NC x 3/4 in. hex cap screws (83), 1/4 in. flatwashers (82), 1/4 in. lockwashers (81) and 1/4 in. hex nuts (80). Tighten.

## OPERATING INSTRUCTIONS



**WARNING:** *Read and thoroughly understand all instructions and safety information before operating this log splitter. Failure to do so may cause serious injury or death. Do not allow anyone to operate this log splitter who has not read this manual. As with all power equipment, a log splitter can be dangerous if assembled or used improperly. Do not operate this log splitter if you have doubts or questions concerning safe operation. Call our customer service department at 1-800-525-8322 to address these concerns.*

*Si no entiende ingles, se prefiere que busque alguien que interprete las instrucciones para usted.*

**IMPORTANT:** *This log splitter comes complete with hydraulic oil and engine oil. Please follow the instruction on page 8 of this manual for filling the hydraulic tank. Refer to the Briggs & Stratton engine owner's manual for information on adding oil.*



**CAUTION:** *DO NOT START OR RUN THE ENGINE BEFORE ADDING OIL IN THE HYDRAULIC RESERVOIR AND OIL IN THE ENGINE.*

**STEP 1:** The hydraulic reservoir must be filled with the oil provided. SAE 20 hydraulic oil is recommended when oil is needed. Automatic transmission fluid can be substituted and should be used instead of hydraulic oil when temperatures are below 32 degrees F. Use only clean oil and take care to prevent dirt from entering the hydraulic reservoir.

Fill the hydraulic tank with at least five gallons of hydraulic oil. Check dipstick after filling. Do not overfill. Oil should be added until the level is in the "OK" range on the dipstick. Total hydraulic capacity is 31.6 quarts.



**CAUTION:** *WHEN TIGHTENING THE BREATHER CAP ON THE TANK, POINT THE HOLE AWAY FROM THE ENGINE AND THE OPERATOR ZONE.*

## ENGINE OIL RECOMMENDATIONS

**NOTE:** Engine oil is provided with your log splitter. Follow instructions in engine owner's manual for filling.

For temperatures above 40 degrees F use an SAE 30W oil. Using multigrade oil may increase oil consumption. Using SAE 30W oil below 40 degrees F will result in hard starting and possible engine bore damage. For temperatures below 40 degrees F use an SAE 10W-30 or SAE 5W-30 oil. Oil capacity is about .56 quarts (18 ounces; .53 liters).

**STEP 2:** After the hydraulic reservoir and the engine crankcase are filled with oil, start the engine. The hydraulic pump should prime itself. With the engine running, move the hydraulic valve lever toward the wedge. This will cause the cylinder to extend and expel air. When the cylinder is fully extended, retract it. Repeat this procedure several times. An erratic movement of the cylinder indicates that there is still air in the system. More oil should then be added to bring the fluid level up to the "OK" range on the dipstick. Total hydraulic capacity is 7.9 gallons. **NOTE:** If the tank is overfilled it will tend to expel oil from the breather cap when the cylinder is retracted. Cycle the cylinder again until it has a constant speed indicating that all air has been expelled.

## STARTING INSTRUCTIONS

*Refer also to the Engine Operating and Maintenance Instructions manual for your log splitter.*

- 1) Check that the fuel switch is in the on position.
- 2) Move the throttle lever to "FAST." Always operate the engine with the throttle lever in the "FAST" position.
- 3) Move choke control lever to "CHOKE" position.
- 4) Grasp the rope handle and pull slowly until resistance is felt. Then pull rapidly to start engine and avoid kickback.
- 5) Allow the engine to warm up. If operating in warm weather, move the choke control lever toward "RUN" a short distance at a time over several seconds. For cold weather operation do this procedure over several minutes. Operate with choke lever in the "RUN" position.
- 6) To stop engine, move the throttle lever to the "STOP" position.



**CAUTION:** *THE FUEL SWITCH MUST BE IN THE "OFF" POSITION WHEN TOWING.*

**NOTE:** The engine maximum governed speed is preset at the factory at 3600 RPM no load speed. When splitting wood the throttle should be set at the maximum speed to develop the horsepower required for the pump.

## OPERATION



**WARNING:** See safety information related to operation of the log splitter on page 3 and 4 of this manual. Make sure that you have the recommended personal protective equipment described on page 1.

- 1) Set up the log splitter in a clear, level area and block the wheels. Make sure that the suction port on the tank is always on the lower side of the log splitter.
- 2) Place a log on the beam against the foot plate. Make sure the log is securely on the foot plate and up against the beam.
- 3) With the engine running, depress the valve handle so that the cylinder will drive the wedge into the log. Extend the cylinder until the log splits or to the end of its stroke. If the log has not completely split after the cylinder has reached the end of its extension, retract the cylinder.  
**IMPORTANT:** Leaving the valve in the "actuate" position at the end of the stroke may damage the pump. Always use extra care when splitting logs with unsquare ends.

**NOTE:** For operation in wooded areas, obtain a spark arrestor for the exhaust system. See the engine operating and maintenance manual and check with your authorized Briggs & Stratton service center. See also Fire Prevention on page 5 of this manual.

**IMPORTANT:** TO EXTEND THE LIFE OF THE HYDRAULIC CYLINDER, AVOID "BOTTOMING OUT" WEDGE PLATE TO THE FOOT PIECE. TO CONFORM WITH INDUSTRY SAFETY RECOMMENDATIONS, THE WEDGE STOPS 2 INCHES FROM THE END OF THE STROKE.

## TOWING

This log splitter is equipped with pneumatic tires, a Class I coupler (2 in. diameter ball required) and safety chains. Before towing, the safety chains must be secured to the hitch or bumper of the vehicle. Local regulations should be checked regarding licensing, lights, towing, etc. Do not exceed 45 mph when towing this log splitter. See also Towing Safety on page 6 of this manual.

## MAINTENANCE

- 1) Consult the operating and maintenance instructions of the engine manufacturer for engine care and maintenance.
- 2) Always check the oil level of the hydraulic reservoir before operation. Operating the log splitter without an adequate oil supply will cause severe damage to the pump.
- 3) Change the oil filter after the first 25 hours of operation. There after change the oil filter every 100 hours or seasonally, whichever comes first.
- 4) If the wedge becomes dull or nicked, it can be removed and sharpened. Remove the 1/2 in. diameter bolt that connects the wedge to the cylinder. The hose from the valve may need to be removed. While the log splitter is in the horizontal position, loosen the hose clamp and disconnect the hose from the valve. Carefully lift the cylinder to allow the wedge to slide forward. The wedge can now be lifted off and sharpened.
- 5) Clean the breather cap after 25 hours of operation. Clean it more often when operated in dusty conditions. To clean, remove the breather cap from the tank and flush with kerosene or liquid detergent to remove the dirt.
- 6) See also Repair and Maintenance Safety on page 4 of this manual.
- 7) All replacement parts must meet manufacturer's specifications.

## PARTS BREAKDOWN MODEL NO. 21-52382

REFERENCE NO.	PART NO.	DESCRIPTION	NUMBER REQUIRED
	401535TS (21-52382)	35 Ton Vertical/ Horizontal Log Splitter Complete	1
1	401412S0	Beam (8" x 10") - Silver	1
2	390935B0	Tank/Axle - Black	1
3	40126800	Tongue Assembly	1
4	39011700	5" Cylinder	1
5	390406SC	Auto-Return Valve	1
6	40143700	Wedge	1
7	39054000	342 cc 1550 Series Briggs & Stratton Engine	1
8	39060100	Filter Assembly	1
	390601A0	Filter Element	1
9	39070900	16 gpm pump	1
10	400824L0	Pump-Engine Coupler (3 pieces)	1
10A	400825L0	1" I.D. Coupler Half (engine side)	1
10B	400826L0	1/2" I.D. Coupler Half (pump side)	1
10C	400827L0	Coupler Spider	1
11	40081800	Pump Mount	1
12	39034100	1/2" Street Elbow	1
13	39031600	Worm Gear Clamp	3
14	39024600	1/2" x 44" Pressure Hose	1
15	39034900	3/4" x 2-1/2" Nipple	1
16	39032000	3/4" NPT x 3/4" Tube	1
17	39038100	3/4" NPT to 1" I.D. Tube Straight Pipe Fitting	1
18	17220900	1/4" SQ x 1-1/2" Square Key Stock	1
19	17220700	1/8" SQ x 1-1/2" Square Key Stock	1
20	39025200	3/4" x 44" Return Hose	1
21	39026400	1" I.D.x 6-3/4" Suction Hose	1
22	O/L	5/16" x 1-1/2" Grade 5 Hex Cap Screw	4
23	O/L	5/16" -18 UNC, Nylon Locknut	4
24	O/L	3/8" Flat washer	4
25	O/L	5/16" x 1" UNF Grade 5 Hex Cap Screw	4
26	O/L	5/16" x 1" Grade 2 Hex Cap Screw	4
27	O/L	5/16" Lockwasher	8
28	39037600	Dipstick	1
29	29037400	Drain Plug	1
30	O/L	M10 Flat Washer	6
31	O/L	M10 x 1.5 x 100mm	1
32	O/L	M10 x 1.5, Nylon Locknut	2
33	40034600	Hitch Coupler for 2" Ball	1
34	O/L	Safety Chain with "S" Hook	2
35	O/L	3/8" "S" Hook	2
36	07080900	7/8" Diameter Pin with 5/8" NF Thread	1
37	O/L	5/8" -18 Nut	1
38	O/L	5/8" Lockwasher	1
39	17033100	Washer with cut	1
40	07090400	1/4" Lynch Pin	1
41	O/L	M10 x 1.5 x 115mm	1
43	O/L	1/2" Lockwasher	1
44	O/L	1/2" x 3-1/2" Grade 5 Hex Cap Screw	1

## PARTS BREAKDOWN MODEL NO. 21-52382

REFERENCE NO.	PART NO.	DESCRIPTION	NUMBER REQUIRED
45	O/L	1/2" Hex Nut	1
46	39034300	1/2" NPT Nipple	1
47	39032000	3/4" NPT x 3/4" Tube	1
48	39031100	3/4" - 1/2" Reducer	1
49	39034200	1/2" - 45° Swivel Fitting	1
50	39026300	1/2" x 27" Hydraulic Pressure Hose	1
51	07073100	Cylinder Pin	1
52	39030200	Swivel Elbow	1
53	390429A0	Control Handle for Valve	1
54	39043400	Chain Link for Valve Handle	1
55	39044200	Spring Cap for Valve	1
--	39044300	Detent Assembly for Valve	1
57	39043500	Mounting Bracket for Valve	1
58	07042900	1/4" Clevis Pin	1
59	17111000	3/32" Straight Cotter Pin	1
63	40031200	Pregreased Wheel Assembly	2
64	40030900	Seal Kit contains 1-grease seal, 2-bearing cones and 2 bearing cups	2
65	--	Grease Seal	2
66	--	Bearing Cone	4
67	--	Bearing Cup	4
68	O/L	3/4" Light Flatwasher	2
69	17012000	3/4" NF Slotted Nut	2
70	O/L	1/8" x 1-1/2" Cotter Pin	2
71	40033200	Dust (Hub) Cap	2
72	100402SPL	Tongue Jack	1
73	071022WC	5/8" x 6-1/4" Pivot Pin	1
74	O/L	1/2" - 3/4" Hairpin Cotter Pin	1
75	O/L	1/2" NC x 4-1/2" Grade 2 Hex Cap Screw	2
76	O/L	1/2" NC Hex Nut	2
77	O/L	1/2" Lockwasher	2
79	40115100	Fender	2
80	O/L	1/4" NC Hex Nut for Fender	4
81	O/L	1/4" Lockwasher for Fender	4
82	O/L	1/4" Flatwasher for Fender	4
83	O/L	1/4" NC x 3/4" Grade 5 Hex Cap Screw for Fender	4

O/L - Obtain Locally. Common fasteners available through hardware and farm stores.

#### Repair Kits

39012600	"O" Ring Kit for 5" x 24" Cylinder 39011700
390423E0	"O" Ring Kit for Valves 390406A0 and 390406SC
390720B0	"O" Ring Kit for Pumps 390705B0 and 39070900

**MODEL NO. 21-52382 LOG SPLITTER**

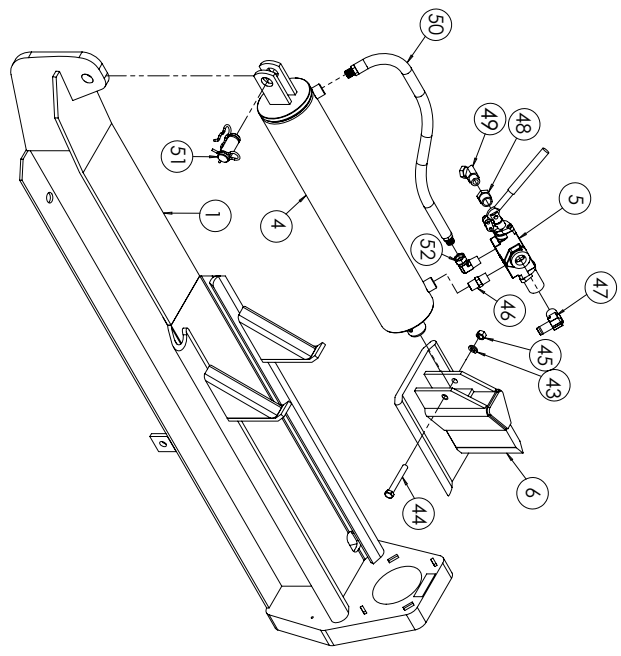
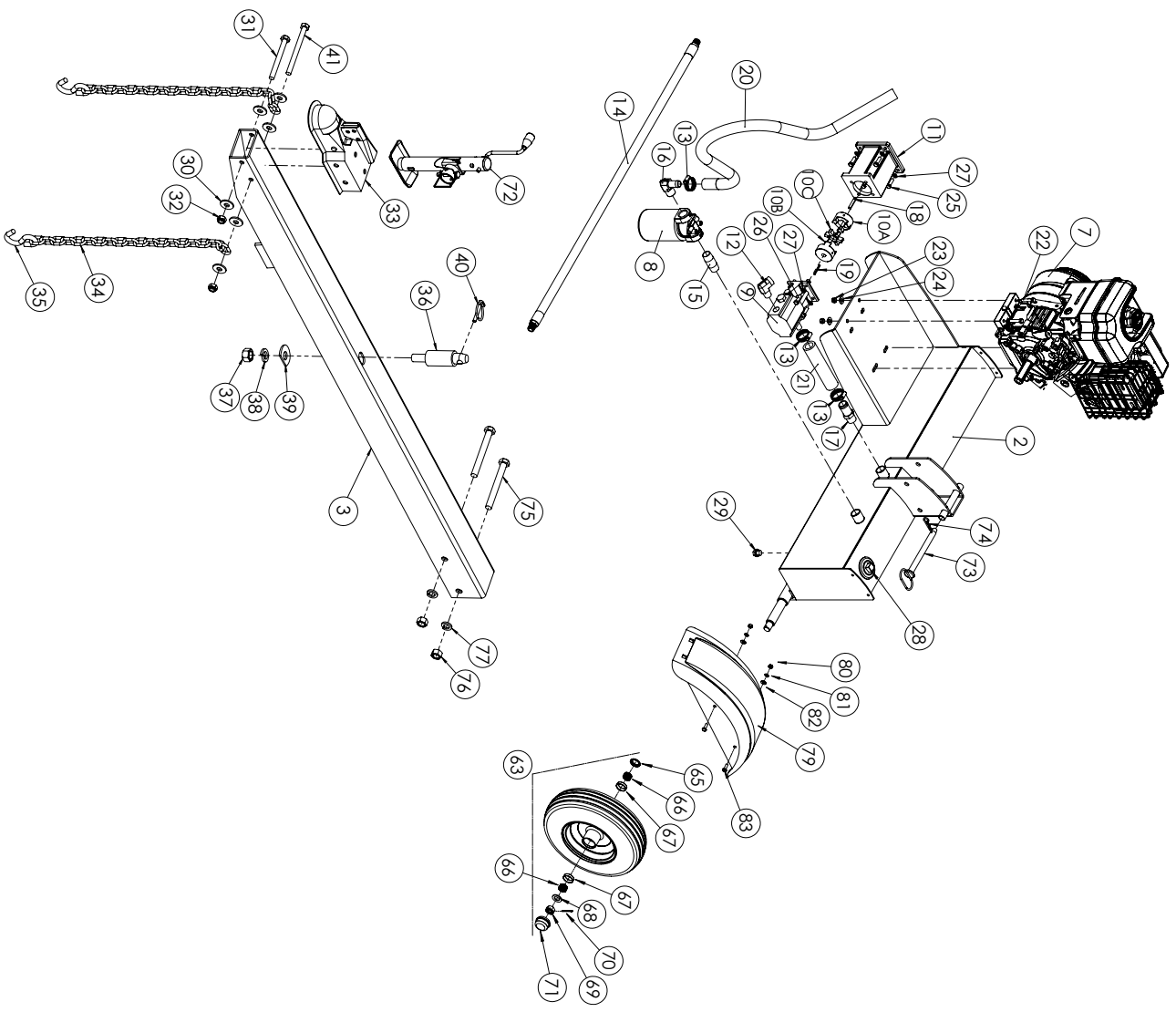

**Valve Assembly**

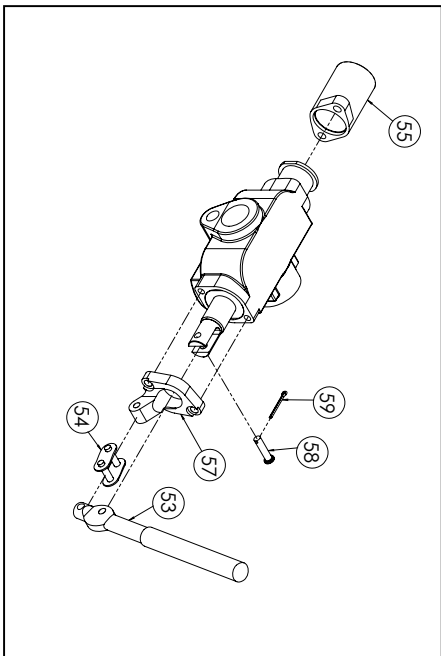

# == NOTES ==

Model No. \_\_\_\_\_

Serial No. \_\_\_\_\_

Date of Purchase \_\_\_\_\_

Place of Purchase \_\_\_\_\_

\_\_\_\_\_  
\_\_\_\_\_  
\_\_\_\_\_

# SPECIFICATIONS

<b>MAXIMUM SPLITTING FORCE</b>	35 Tons
<b>ENGINE</b>	342cc 1550 series Briggs & Stratton
<b>CYLINDER</b>	5" Diameter X 24" Stroke
<b>VALVE</b>	Auto-Return
<b>PUMP</b>	Two- Stage 16 gpm
<b>MAXIMUM LOG LENGTH</b>	26"
<b>CYCLE TIME *</b>	15 Seconds
<b>WHEELS</b>	4.80 X 8" Pneumatic Tires on Rims
<b>WEDGE</b>	7" High with Spreader Wings
<b>BEAM SIZE</b>	8" X 10"
<b>TOTAL HYDRAULIC CAPACITY</b>	7.9 Gallons
<b>FILTER</b>	Spin-On Replaceable
<b>HEIGHT</b>	72" in Vertical Position 42" in Horizontal Position
<b>LENGTH</b>	78"
<b>WIDTH</b>	49"
<b>SHIPPING WEIGHT</b>	660 lbs.
* Ideal case cycle time. Actual cycle time will vary depending on temperature, altitude, engine speed, pump efficiency, etc.	

Note: Huskee log splitters are manufactured by Special Products Co.



*A brand of Special Products Co.*  
15000 W. 44th Ave. Golden Colorado 80403  
303-279-5544 Toll Free USA 800-525-8322 Fax 303-278-3432  
Email: speeco@speeco.com Web: www.speeco.com